

2011 PreAP Harmonic Motion 4

- * To double the period of a pendulum, by what factor does its length need to be changed?
- If a spring-mass system has its mass halved and its spring constant tripled, by how much does the spring's period change?
- A pendulum has a period of 0.72 seconds on the earth (use 9.8). On planet Zorg it has a period of 0.55 seconds. What is the acceleration due to gravity on Zorg?

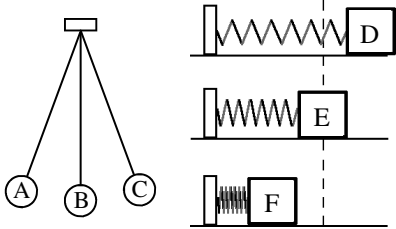

	Pendulum	Spring
PE = max	A, C	D, F
PE = min		
KE = max		
KE = min		
v = 0		
v = max		
acc = max		
acc = 0		
F = max		
F = 0		

- Use the pictures of the pendulum and spring-mass system shown at the left. Fill in the table, deciding at which position (or positions) the conditions exist. The first one is done for you. The pendulum and spring do not stop. (Notice that at the equilibrium position (B or E) there is no restoring force. That's why they will eventually come to rest there. So if there is no restoring force, there is no acceleration.)

- What are the wavelengths of the first four possible harmonics on a 1.2 m long string?
- * What are the frequencies of the first two possible harmonics on a 30 cm closed pipe. Use 343m/s for the speed of sound in air.

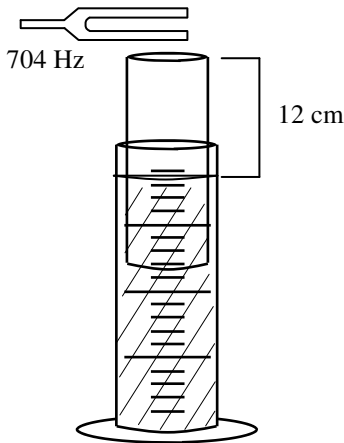

- A graduated cylinder has water in it almost to the top. A smaller tube of glass is set inside. A tuning fork is struck and it is put above the movable tube. The inside tube is adjusted until the tube amplifies the sound of the tuning fork.
 - * The inside tube gets loud due to r_____.
 - Is the inside tube open to the air at both ends or is it closed at one end?
 - Is the amount of the wave in the cylinder 1/2 or 1/4 of λ ?
 - What is the wavelength of the harmonic produced in the tube (λ_1)?
 - Since you know the wavelength and the frequency, calculate the speed of sound in air for this room at this time.

p. 482 in your book (on online) —Be sure to read about speed of sound at the bottom and read the table.

- Which has a faster speed of sound? A. Air or helium? B. Air or steel?

From the notes "Ancillary Sound Topics".

- What are beats and how are they created?
- Two notes vibrate with frequencies of 125 Hz and 123 Hz, how many beats are heard?
- If one note has a frequency of 350 Hz and 3 beats per second (a beat frequency of 3 Hz) are heard, what frequency is the other note?
- A clarinet and a trumpet playing the same note sound different. Explain and use the correct vocab word.

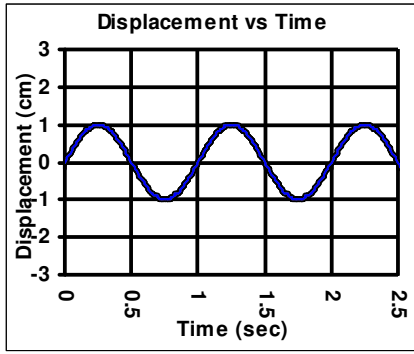

Graph A: Amplitude: _____
Period: _____

Spring ____ Pendulum ____

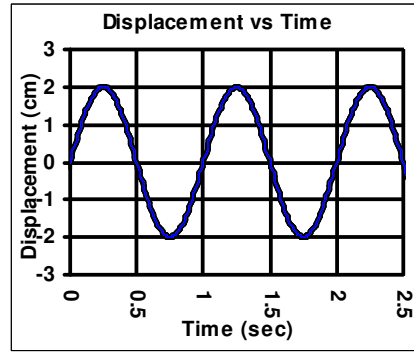

Graph B: Amplitude: _____
Period: _____

Spring ____ Pendulum ____

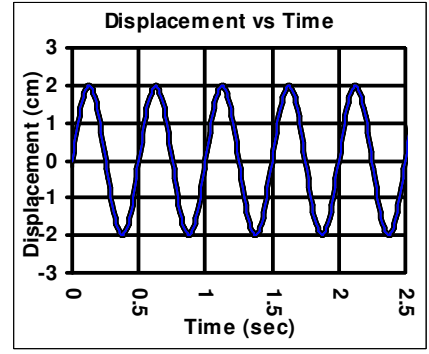

Graph C: Amplitude: _____
Period: _____

Spring ____ Pendulum ____

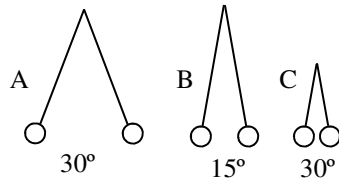
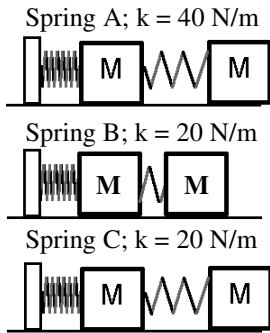

13. A. Find the amplitude and period for each of the graphs above, writing beneath the graph.
B. * Which graph has an amplitude different than the others?
C. * Which spring has an amplitude different than the others?
D. Which pendulum an amplitude different than the others?
E. Using this same logic, decide which graph belongs to which pendulum or spring. (Study Help available)



14. A pulse wave of amplitude “A” is sent down a slinky from the left. The reflected wave is shown on the right side of the slinky.
- Is the right side of the slinky fixed or unfixed?
 - What will be the amplitude of the slinky when the waves cross?
 - Is this constructive or destructive interference?

15. A pulse wave of amplitude “A” is sent down a different slinky from the left. The reflected wave is shown on the right side of the slinky.
- Is the right side of the slinky fixed or unfixed?
 - What will be the amplitude of the slinky when the pulses cross?
 - Is this constructive or destructive interference?

16. Using the table at the bottom right, if a sound increases by 30 dB, by how much does the intensity change?
17. A sound source generates 0.50 W of power.
- * What is the intensity of the sound 20 meters away?
 - * How many decibels is that (use the table)?
 - What is the intensity of the same source, 40 meters away?
 - By what factor does the intensity change if the distance is four times as great?
18. *A sound source puts out 1.2W of power. How far away is a 1.2W power source if the intensity is $1.062 \times 10^{-2} \text{ W/m}^2$?

Intensity is energy flowing thru a surface area. It relates to loudness, which is amplitude. Remember: more amplitude means more energy.

Intensity Due to a Spherical Wave

$$\text{intensity (in } W/m^2) = \frac{\text{Power (in watts)}}{4\pi r^2} \leftarrow \text{Surface area of a sphere}$$

Intensity (W/m^2)	dB
1.0×10^{-12}	0
1.0×10^{-11}	10
1.0×10^{-10}	20
1.0×10^{-9}	30
1.0×10^{-8}	40
1.0×10^{-7}	50
1.0×10^{-6}	60
1.0×10^{-5}	70

Intensity (W/m^2)	dB
1.0×10^{-4}	80
1.0×10^{-3}	90
1.0×10^{-2}	100
1.0×10^{-1}	110
1.0×10^0	120
1.0×10^1	130
1.0×10^3	150

1) Since T is prop to the sq rt of ℓ , then 4ℓ gives $2T$. out the other one on your own. 7A) resonance round to $1 \times 10^{-4} \text{ W/m}^2$ B) 80 dB
6) closed pipe: $\lambda_1 = 4L = 4(.3) = 1.2 \text{ m}$; $v = f\lambda$, so $f_1 = 286 \text{ Hz}$. Figure 13B) Graph A; 13C) Spring B 17A) $9.95 \times 10^{-5} \text{ W/m}^2$ for the chart, 18) 3 m