

## PreAP Harmonic Motion 10

1. What are the wavelengths of the first four possible harmonics on a 1.2 m long string?
2. \* What are the frequencies of the first two possible harmonics on a 30 cm closed pipe. Use 343m/s for the speed of sound in air.

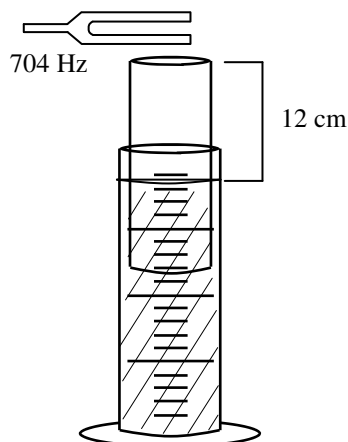

3. A graduated cylinder has water in it almost to the top. A smaller tube of glass is set inside. A tuning fork is struck and it is put above the movable tube. The inside tube is adjusted until the tube amplifies the sound of the tuning fork.
  - A. \* The inside tube gets loud due to r\_\_\_\_\_.
  - B. Is the inside tube open to the air at both ends or is it closed at one end?
  - C. \* Is the length of the wave in the cylinder 1/2 or 1/4 of  $\lambda$ ?
  - D. \* What is the wavelength of the harmonic produced in the tube ( $\lambda_1$ )?
  - E. Since you know the wavelength and the frequency, calculate the speed of sound in air for this room at this time.
4. An open pipe has a third harmonic of 520 Hz. What is the length of the pipe if the speed of sound on this day is 352 m/s (*Boy, is it hot!*).
5. \* A closed pipe is 18 cm long. If the second possible harmonic is 1400 Hz, what is the speed of sound that day? (*And is it a hot day?*)
6. \* If the speed of sound in air is 340 m/s, what is the wavelength of a 12 kHz sound?
7. What is the frequency of a sound wave in air that has a wavelength of 12mm (*use  $v = 340$  m/s*)?
8. A string has a length of 0.8m.
  - A. What is the wavelength of the natural frequency of the string?
  - B. What are the wavelengths of the first 3 harmonics of the string?
  - C. If the speed of sound in air is 342 m/s, what is the frequency of the fundamental for this string?
  - D. What are the frequencies for the first 3 harmonics of the string?

*Let's learn where this idea of "decibels" come from. It is all related to intensity. Intensity is defined as energy flowing thru a surface area. When a sound source produces a sound wave the power spreads out like blowing up a balloon: as a balloon gets bigger (greater area) the balloon gets thinner (less power in any given area). The more power hits your ear (a given area) the louder it is and the more decibels you hear.*

9. \* A power source puts out 3W. What is the intensity 4.5 m away?

*Intensity Due to a Spherical Wave*

$$\text{intensity (in } W/m^2) = \frac{\text{Power (in watts)}}{4\pi r^2} \leftarrow \text{Surface area of a sphere}$$

10. \*A sound source puts out 1.2W of power. How far away is a 1.2W power source if the intensity is  $1.062 \times 10^{-2} W/m^2$ ?

The table at the right shows how intensity relates to decibels. Also, notice how I broke down the jump between 40 and 50 dB.

11. A sound source generates 0.50 W of power.
- \* What is the intensity of the sound 20 meters away?
  - \* How many decibels is that (*use the table*)?
  - What is the intensity of the same source, 40 meters away? (*Notice that the distance doubled.*)
  - By what factor would the intensity change if the distance was four times as great?

Intensity (W/m <sup>2</sup> )	dB
$1.0 \times 10^{-12}$	0
$1.0 \times 10^{-11}$	10
$1.0 \times 10^{-10}$	20
$1.0 \times 10^{-9}$	30
$1.0 \times 10^{-8}$	40
$10 \times 10^{-8}$ or $1.0 \times 10^{-7}$	50
$1.0 \times 10^{-6}$	60
$1.0 \times 10^{-5}$	70
$1.0 \times 10^{-4}$	80
$1.0 \times 10^{-3}$	90
$1.0 \times 10^{-2}$	100
$1.0 \times 10^{-1}$	110
$1.0 \times 10^0$	120

$1.0 \times 10^{-8}$	40
$2.0 \times 10^{-8}$	42
$5.0 \times 10^{-8}$	45
$7.0 \times 10^{-8}$	47
$1.0 \times 10^{-7}$	50

Q2) closed pipe:  $\lambda_1 = 4L = 4(.3) = 1.2$  m;  $v = f\lambda$ , so  $f_1 = 286$ Hz. Figure out the other one on your own.

Q3A) resonance      Q3C)  $L = \lambda/4$       Q3D)  $4L$  (so figure it out)

Q5) so  $\lambda_1 = 4L = 4(.18) = 0.72$  m. 2nd possible is H3, so  $f_3 = 1400$  Hz, so  $f_1 = 467$ Hz, so  $v = f\lambda = 336$  m/s

Q6)  $v = f\lambda$      $\lambda = v/f = 340/12,000 = .028$  m or 2.8 cm

Q9) 
$$I = \frac{3}{4\pi(4.5)^2} = 1.1 \times 10^{-2} \text{ W / m}^2$$

Q10) 3 m

Q11A)  $9.95 \times 10^{-5} \text{ W/m}^2 = 10 \times 10^{-5} \text{ W/m}^2 = 10^{-4} \text{ W/m}^2$   
 B) which is 80dB