

1. Scalar or vector?

- |                                       |                      |                                      |
|---------------------------------------|----------------------|--------------------------------------|
| A. ___ Does not need direction.       | D. ___ Velocity.     | G. ___ Number of pennies on a table. |
| B. ___ Needs magnitude and direction. | E. ___ Speed.        | H. ___ Mass                          |
| C. ___ Needs amount only.             | F. ___ Acceleration. | I. ___ Pressure.                     |

2. The graphic at the left shows the path of a projectile shot ground to ground.

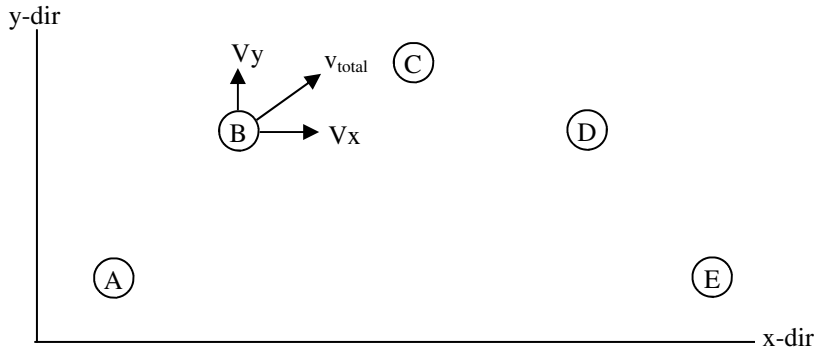

- On the way up, the y-velocities will: increase; decrease; stay the same?
- On the way down, the y-velocities will:
- As it goes from A to E, the x-velocities will:
- Draw the x and y velocities on each letter. Use longer arrows for greater velocity (they don't have to be perfect).
- Draw the total velocity (the speed) of the projectile at each point. The one at point B is done for you, as an example.

3. Answer the following questions about the projectile positions above. The projectile is launched from the ground to the ground. Its initial velocity is  $V$  and its initial angle is  $\theta$ . Some questions may have more than one answer.

- Its initial x-velocity is:
- Its initial y-velocity is:
- Its total velocity at point C is:
- Its acceleration at point D is (and give direction):
- Its x-velocity at D is:
- Where is its speed the greatest ( $V_{total}$ )?
- Where is its acceleration the smallest?
- Compared to its horizontal speed at point B, its horizontal speed at D is:

4. What is the shape of a projectile's path?

5. Projectile or not?

- \_\_\_ A falling piece of paper?
- \_\_\_ A dropped rock?
- \_\_\_ A rock that is thrown downward after it is let go?
- \_\_\_ A balloon that is thrown?

6. Four projectile are launched from the ground with the same initial velocity. Their angles of fire are:  $30^\circ$ ;  $45^\circ$ ;  $60^\circ$ ;  $80^\circ$ .

- Which one has the most hang time (greatest time in the air)?
- Which has the greatest  $V_x$ ?
- Put them in order from greatest range to least range. If they are the same, say so.

7. Three projectiles are shot horizontally with the given velocities shown below. I and II are shot from the same height.

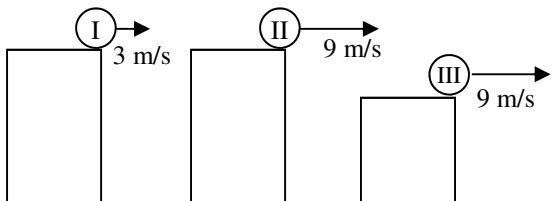

- \_\_\_ Which is in the air for a greater time: I or II?
- \_\_\_ Which is in the air for less time: II or III?
- \_\_\_ Has the greater range: II or III?
- \_\_\_ Has the greater range: I or II?
- Give two ways to increase the range of I: