

1. After working the circuit at the left, answer the following questions.

- Just by looking, which resistor uses the least amount of voltage?
- How much voltage does a wire use?
- * Which resistor has the greatest current?
- What is the total voltage?
- What is the total resistance?
- * What is the total current?
- How many paths are there for the current to flow?
- * How much current is flowing thru the 3Ω resistor?
- * Given that $V = IR$ (always) how much voltage does the 3Ω resistor use?
- Since resistors use up voltage, how much voltage is left at letter E?

*We haven't talked about electrical power, yet, but $P = VI$.
P is still in watts.*

- * How much power is used by the 3Ω resistor?
(Use $P_{3\Omega} = V_{3\Omega} I_{3\Omega}$)
- Calculate the voltage used by the 4Ω resistor.
- What is the voltage difference between point I and point H?

Let's work with power a bit more.

- * Remember back to energy. What is the basic equation for power?
- What are the units for power?
- * What are the units for power, broken up?

Now, let's combine the two equations.

- A series circuit has a total voltage of 3.5 volts and draws 0.25 amps.
 - * Calculate the total power generated by the battery.
 - Change your units, breaking down watts.
 - * How much energy does the circuit use in 2 minutes?
- Given that $V = IR$ and $P = VI$. Now, let's combine these two equations.
 - * Write an equation for power that does not have voltage in it. (Substitute $V = IR$ into $P = VI$.)
 - * Write an equation for power that does not have current in it. (Solve for I in the first equation and substitute into the second equation.)
- Choosing the correct equations for power ($P = VI$, $P = I^2R$, or $P = V^2/R$), how does the power used change if:
 - * The voltage is doubled.
 - * The current is doubled and the resistance is doubled.
 - The voltage is doubled and the resistance is halved.
 - The voltage is halved and the current is doubled.

And if you don't remember: $1\text{ k}\Omega = 1000\ \Omega$ and $1\text{ mA} = 0.001\text{ A}$ (or $1 \times 10^{-3}\text{ A}$).

- * A $45\text{ k}\Omega$ resistor has 65 mA flowing thru it. How much power does it dissipate?

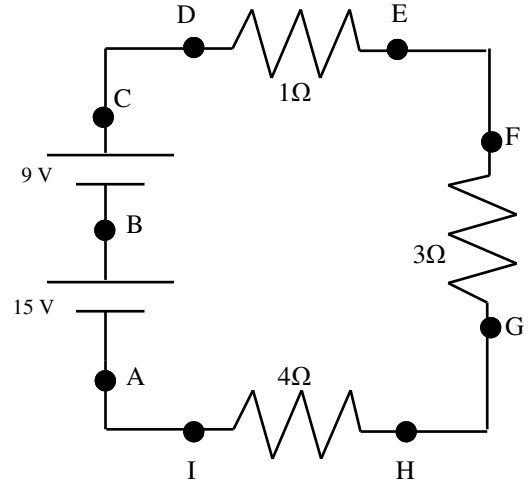

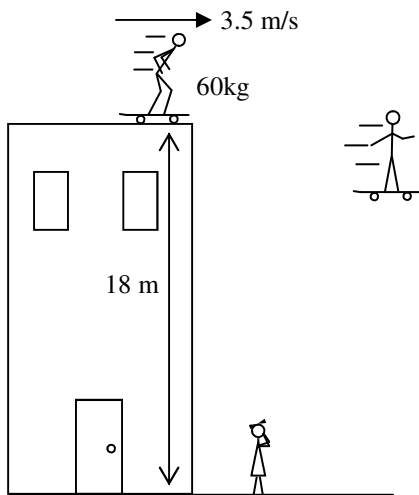

9. In his latest crazy attempt to impress Slim Kim, Slim Jim rides his skateboard off the top of a horizontal roof.
- What kind or kinds of energy does he have just as he leaves the roof?
 - * Calculate his total energy as he leaves the roof.
 - How much kinetic energy does he have when he slams into the ground?
 - * Calculate how far away from the edge of the building he lands (Δx).

1C: same (aren't they in series?)

1F: 3A (24/8)

1H: 3A

1I: 3V

1K: 27W

2: $P = W/t$ 4: watts = J/sec

5A: 0.875watts

5C: mult by 120 sec = 105 joules

6A: $P = I^2R$ 6B: $P = V^2/R$

7A: have to use $P = V^2/R$, since if V increases, so will I. So x4

7B: use $P = I^2R = (x4)(x2) = x8$

9B: 11167 joules

9D: 6.7 m (1.92 sec)