

PreAP Circuits 11

1. Wire 1 has a cross-sectional area of 2.5 cm^2 . Wire 2 has a cross-sectional area of 3.0 cm^2 . If they are comprised of the same material, which has the greatest resistance?

Let me help you understand how to use units to solve questions. We already know that $W = J/s$, $A = C/s$, and $V = J/C$.

$$15W = \frac{15J}{1\text{sec}} \text{ then } \frac{15J}{1\text{sec}} \left(\frac{4\text{sec}}{1} \right) = 60J \quad \text{but } \frac{15J}{1\text{sec}} \text{ can become } \frac{1\text{sec}}{15J} \text{ so } \frac{1\text{sec}}{15J} \left(\frac{60J}{1} \right) = 4\text{sec}$$

Always put what you want to calculate on top of the fraction. If you are looking for coulombs, put coulombs on top, etc. $12V = 12J/C$ which can become $1C/12J$ and calculating coulombs becomes easy. Let's try this.

2. * A battery does 8 J of work to push 12mA thru a 6k Ω resistor. How many coulombs of charge flowed thru the resistor?
3. * A 660 Ω resistor has 12V of potential difference (voltage) across it. How long does it take for 5.5 C of charge to flow thru the resistor?
4. * A 560 Ω and a 320 Ω resistor are in parallel. If the 320 Ω resistor uses 12W of power, what is the potential difference (voltage) across the 560 Ω resistor?

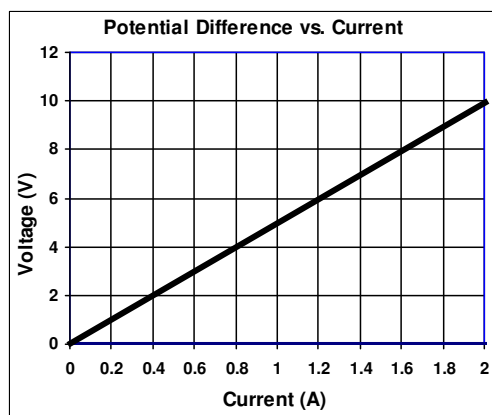

5. The potential difference across a resistor is changed. The current is recorded and graphed, as shown.
- Calculate the resistance of the resistor.
 - * Calculate the power dissipated by the resistor for the entire graph.
 - Is the resistor Ohmic or Non-Ohmic?
 - How would the graph change if the wire were made longer?
 - Which variable did they manipulate (is independent)?
 - Which variable is responsive (dependent)?
 - Then why is voltage on the y-axis?

6. * Find the current flowing thru and the voltage used by the 8 Ω resistor in the circuit below. You will want to redraw at least once, maybe twice. I made the numbers work out nice. You're welcome, again. (S_1 stands for "switch 1".)

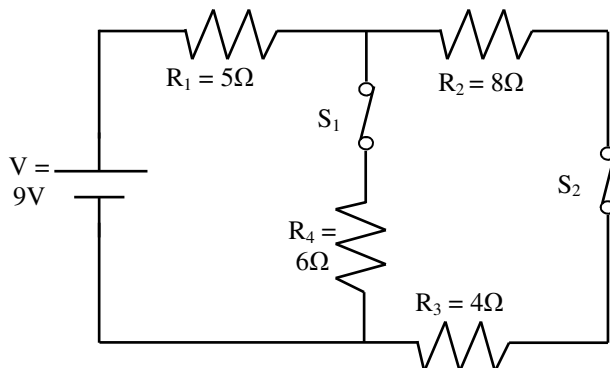

7. Now, switch 1 is opened. Calculate the new current and voltage used by the 8Ω resistor.

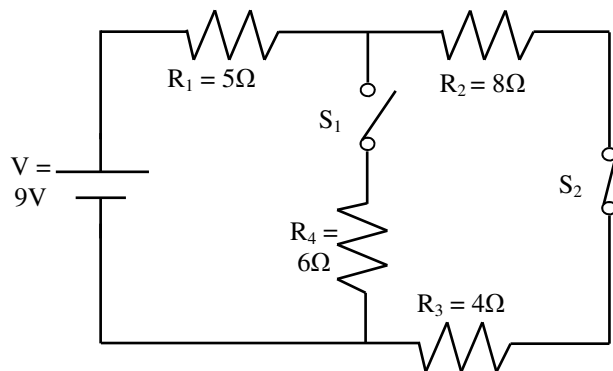

8. Switch 1 is closed again. In the circuit above, draw the following meters, being sure to connect them correctly. (*Study Help on “Meters” available.*)
- * Draw an ammeter to measure the current flowing thru the 4Ω resistor. Label it A_1 .
 - Draw an ammeter to measure the total current of the circuit. Label it A_t .
 - Draw a voltmeter to measure the potential difference (voltage) across R_2 .
 - Draw an ohmmeter to measure the actual resistance of R_1 .

Q2: 0.11 C (find volts first)

Q3: 305.5sec (find current first)

Q4: 62 V (since they are in parallel, they have the same voltage.)

Q5B: find area, since $P = VI$

Q6: Total current = 1A

Q8A: Draw a circle on top of the wire on either side of the resistor. Remember than an ammeter has to break the circuit. OR—an ammeter is always in SERIES with the device it is reading.