

Name: \_\_\_\_\_

Period: \_\_\_\_\_

## Light and Optics In Class Review 2

1. A. For the diagram at the right what is the angle of reflection?  
B. What is the focal length of the mirror?  
C. Which is the real side of the mirror: top or bottom?

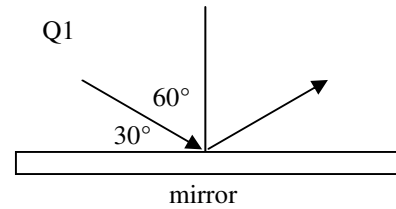

2. Find the critical angle for light passing from glass to water.

3. What is the speed of light in a cubic zirconium ( $n = 2.20$ )?

4. Why does light refract? (*Be specific as to direction, too.*)

5. Decide which way light will refract as it passes from the top medium into the bottom medium.

i.

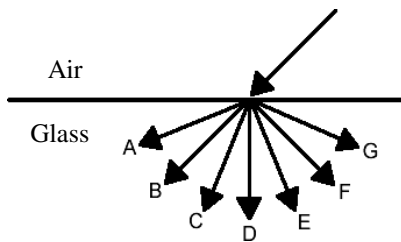

ii.

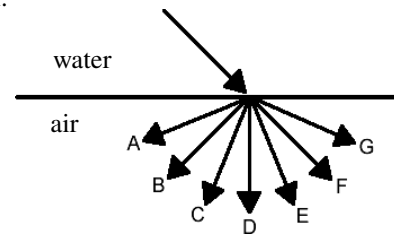

6. In example i, above,
  - A. Which substance has a faster speed of light?
  - B. Which substance has a higher frequency?
  - C. Which substance has a longer wavelength for light?

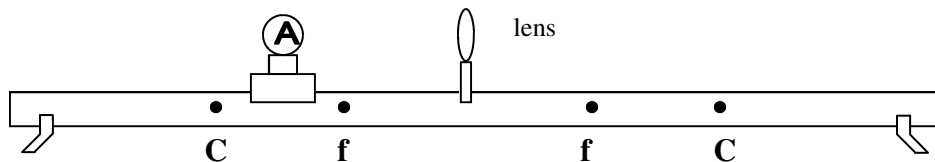

7. Use the above setup to answer the following questions. This information was learned in the "Convex Lens" Lab.
  - A. Label the image.
  - B. Will the image be real or virtual?
  - C. Will the image be magnified, reduced, or 1?
  - D. Which way would you move the object to increase the size of the image?
  - E. Draw where you think the image might be.
  - F. Where would you put the object if you wanted a magnification of 1?
  - G. Where would the image be if you put the object at  $f$ ?

8. (*From the July 2004 Exit Level TAKS test.*) When trying to spear a fish in water, a person needs to take into account the way light bends as it moves from water into air. The bending of light as it passes from one medium into another is known as—

Name: \_\_\_\_\_

Period: \_\_\_\_\_

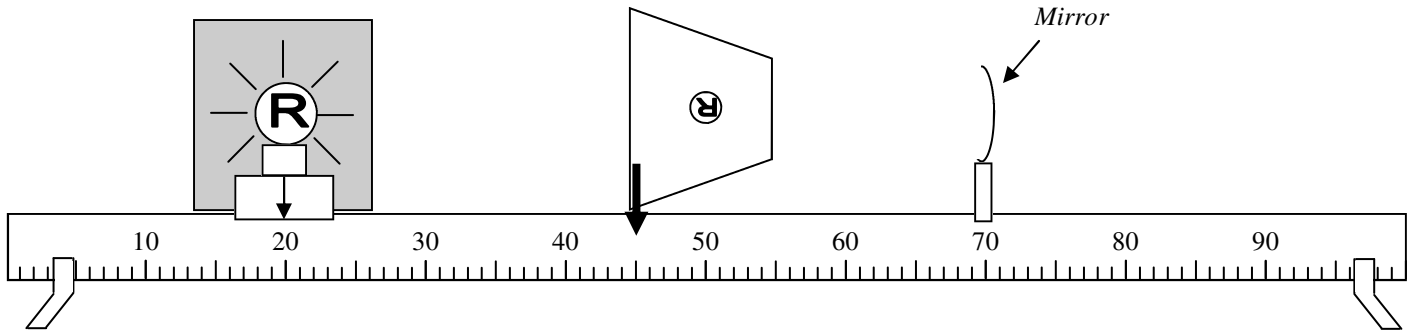

9. The above shows a light source creating an image on a piece of paper from a mirror.
- A. Mark  $p$ ,  $q$ ,  $h$  and  $h'$ .
  - B. What kind of mirror is it?
  - C. Will the image be real or virtual?
  - D. Why?
  - E. Which is bigger  $p$  or  $q$ ?
  - F. So, without calculating, will the image be magnified or reduced?
  - G. + or -:  $p$  \_\_\_\_;  $q$  \_\_\_\_;  $f$  \_\_\_\_;  $h$  \_\_\_\_;  $h'$  \_\_\_\_.
  - H. Calculate the focal length and magnification of the lens.

Total internal reflection  
Photon  
Electromagnetic Spectrum

Polarizer  
Critical angle  
Laser

Fiber Optics  
Index of Refraction  
Dispersion

10. Use this word bank for the following definitions. Words will be used more than once.

- A. Includes radio waves, x-rays, and microwaves.
- B. Is the principle used by fiber optics.
- C. Two of these at right angles can cancel out light.
- D. If this number is bigger, the light refracts more.
- E. A single packet or particle of light.
- F. Angle at which light refracts at  $90^\circ$  to the surface.
- G. When white light separates into its different colors.
- H. A light source that has only one wavelength of light.
- I. Given off when the excited electrons in the atom fall to a lower orbit.
- J. A tube that can guide light, even around corners.
- K. Beyond this light reflects instead of refracts.
- L. Will not spread out when passed thru a prism.
- M. All light, both visible and invisible.
- N. If the incoming ray is within this amount light will refract thru.
- O. When light becomes trapped inside a substance.
- P. After passing thru one of these all of the light is in one direction.
- Q. Light amplification by stimulated emission of radiation.
- R. A number that tells you how slow light moves in a substance.
- S. What happens to white light when it passes thru a prism.
- T. Works by total internal reflection.

11. The diagram at the right shows light passing from air into a piece of glass.
- A. What is the incoming angle?
  - B. Calculate the refracted angle (in the glass).

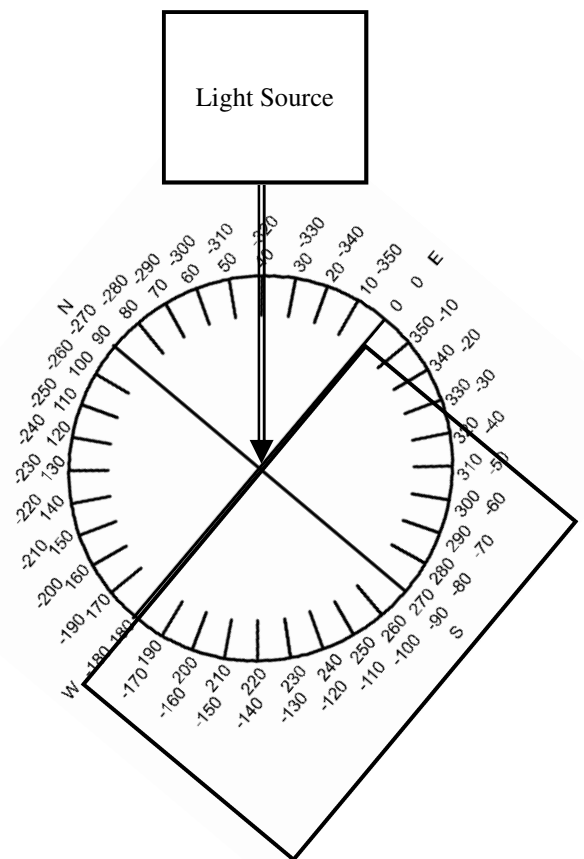

- C. Draw the reflected light ray inside the glass block.